

Ceiling Canopy LED

CNP10AC

INSTALLATION SHEET

START FROM HERE

- Make sure power is completely off at the fuse box.
- Have your fixture installed by a qualified licensed electrician
- Prepare everything in a clear area.
- Wear gloves at all times during this installation.
- Read instructions carefully before you start assembly.
- Keep this instruction sheet for future reference.

Technical Support: 1-877-452-6858

Please Note:

- All Kuzco LED fixtures come with pre-wired LED module(s).
- Unless instructed to do so, please do not touch any part of the LED module(s) as any unnecessary contact with the module could cause permanent damage.
- For dimming, an ELV (Electronic Low Voltage) type of dimmer is required.

- 1.** Remove the canopy from it's original packaging. Remove the mounting plate **(1c)** from within the canopy **(2a)** by removing the decorative nuts **(2b)**. Attach the mounting plate to the electrical junction box using the screws **(1e)** provided in the hardware package. Make sure to reinforce the wood behind the drywall and use the woodscrews and plastic anchors **(1f)** for extra support.
- 2.** Before you mount the canopy to the mounting plate select the desired length you wish the pendant to hang. Loosen the screws in each canopy nipple **(2c)** and push/pull the cable. Tighten the screw back to secure the cable in place
- 3.** You are now ready to mount the canopy **(2a)** to the mounting plate **(1c)**. First connect all wires correctly G ground to ground, N neutral wire (white to white), L live wire (black to black) with provided marettes **(1b)** from the hardware package. Align the hole in the canopy to the threaded stud screws **(1d)** hanging downward from the mounting plate. Push the canopy up towards the ceiling so the stud screws **(1d)** clears through the holes in the canopy **(2a)**. You can now screw on the decorative nuts **(2b)** onto the threaded studs **(1d)** This will securely connect the canopy **(2a)** to the mounting plate **(1c)**.
- 4.** You have now completed the installation of your canopy, enjoy.

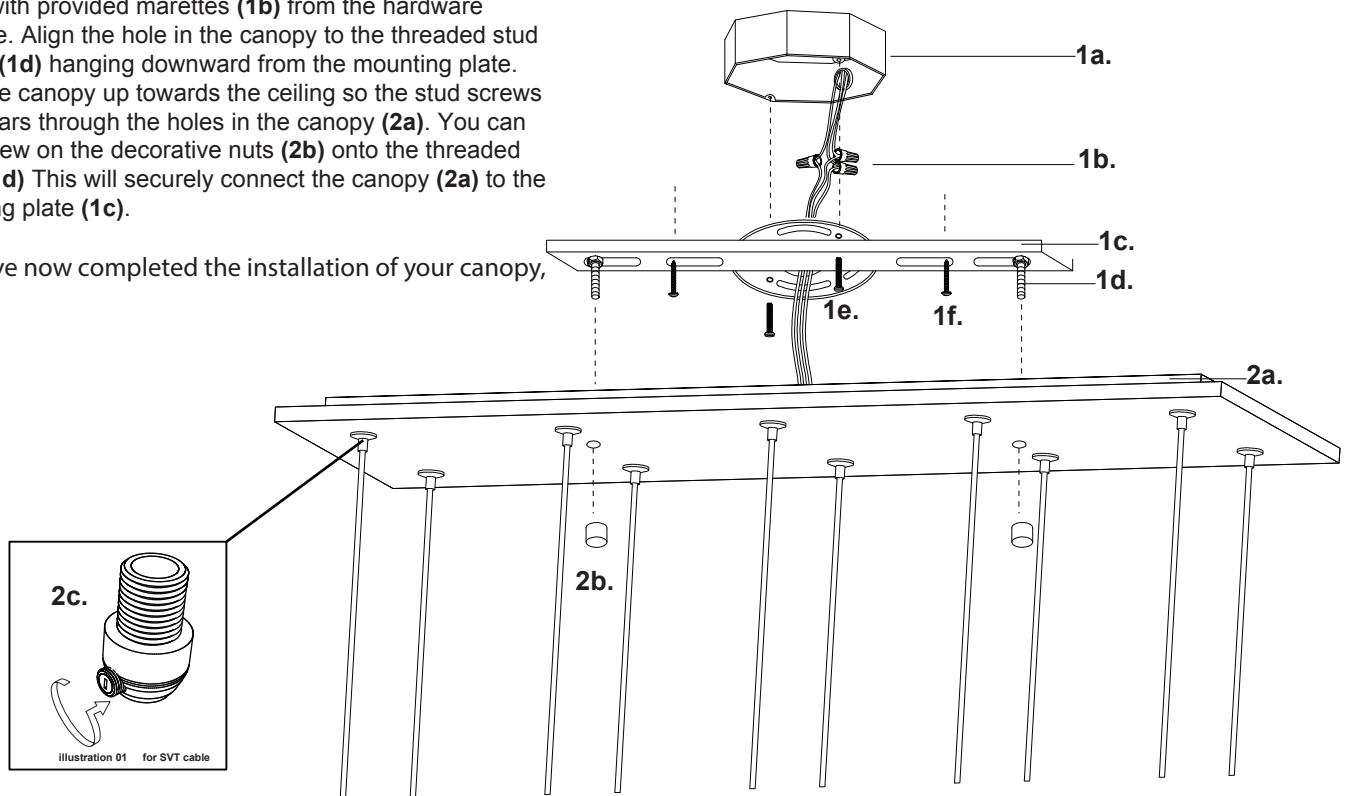

KUZCO LIGHTING

19054 28th Avenue Surrey, BC Canada V3S 6M3
T: 604 538 7162 TF: 1-855 85 KUZCO F: 604 538 7196
W: kuzcolighting.com
20170621